





2" Food Processing with Metallic Center Section

SPFP20

SPFP20 Models

- SPFP20NPT
- SPFP20NPS 
- SPFP20SSS 
- SPFP20SST
- SPFP20NPP 
- SPFP20SSP 

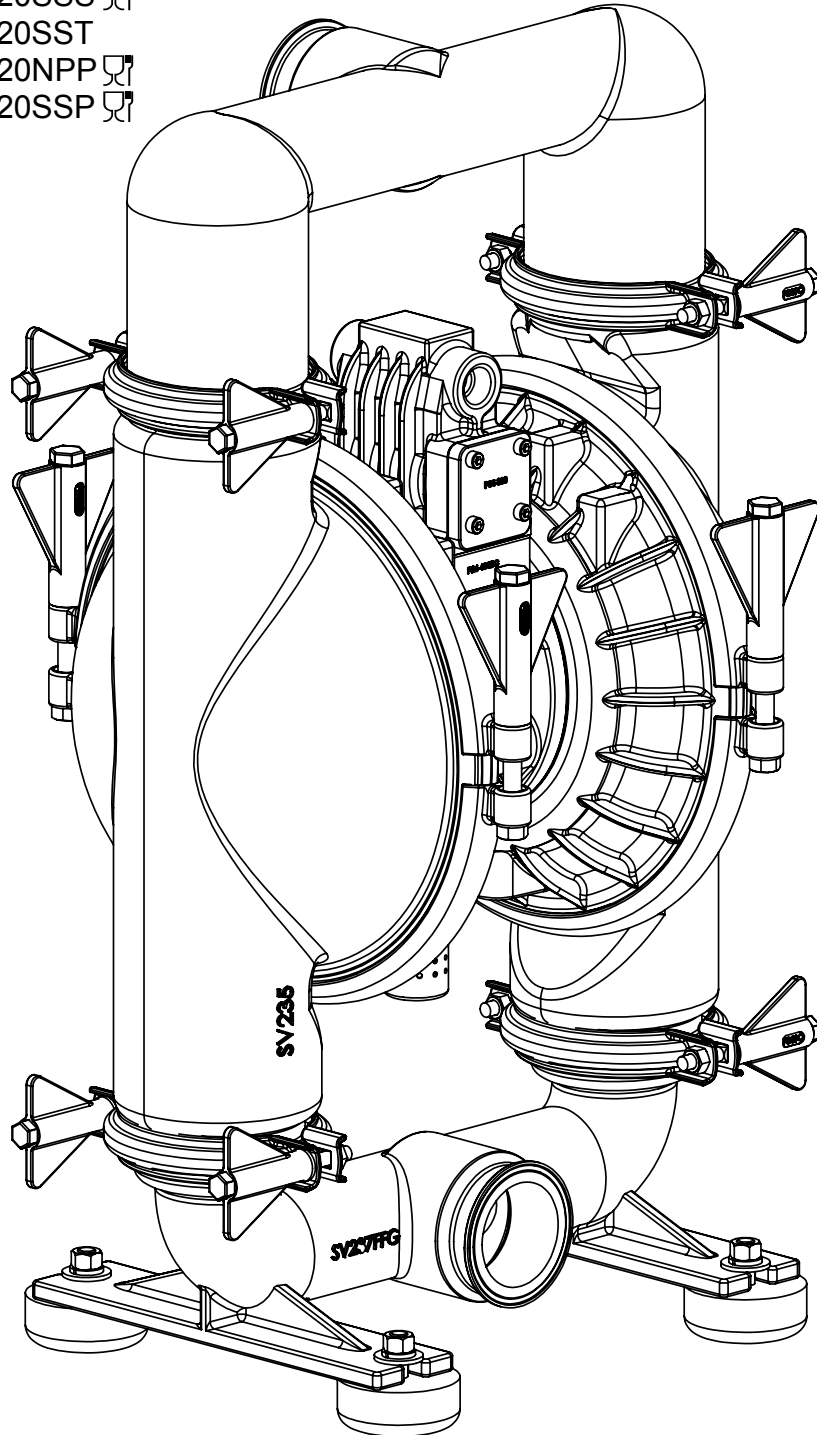

STANDARD
Pump, Inc.

1: PUMP SPECS

2: INSTAL & OP

3: EXP VIEW

4: CERTIFICATES

Safety Information

IMPORTANT



Read the safety warnings and instructions in this manual before pump installation and start-up. Failure to comply with the recommendations stated in this manual could damage the pump and void factory warranty.



When the pump is used for materials that tend to settle out or solidify, the pump should be flushed after each use to prevent damage. In freezing temperatures the pump should be completely drained between uses.

CAUTION



Before pump operation, inspect all fasteners for loosening caused by gasket creep. Retighten loose fasteners to prevent leakage. Follow recommended torques stated in this manual.



Nonmetallic pumps and plastic components are not UV stabilized. Ultraviolet radiation can damage these parts and negatively affect material properties. Do not expose to UV light for extended periods of time.



WARNING
Pump not designed, tested or certified to be powered by compressed natural gas. Powering the pump with natural gas will void the warranty.

WARNING



When used for toxic or aggressive fluids, the pump should always be flushed clean prior to disassembly.



Before maintenance or repair, shut off the compressed air line, bleed the pressure, and disconnect the air line from the pump. Be certain that approved eye protection and protective clothing are worn at all times. Failure to follow these recommendations may result in serious injury or death.



Airborne particles and loud noise hazards. Wear eye and ear protection.



In the event of diaphragm rupture, pumped material may enter the air end of the pump, and be discharged into the atmosphere. If pumping a product that is hazardous or toxic, the air exhaust must be piped to an appropriate area for safe containment.



Take action to prevent static sparking. Fire or explosion can result, especially when handling flammable liquids. The pump, piping, valves, containers and other miscellaneous equipment must be properly grounded.



This pump is pressurized internally with air pressure during operation. Make certain that all fasteners are in good condition and are reinstalled properly during reassembly.



Use safe practices when lifting

Grounding the Pump

To be fully groundable, the pumps must be ATEX Compliant.

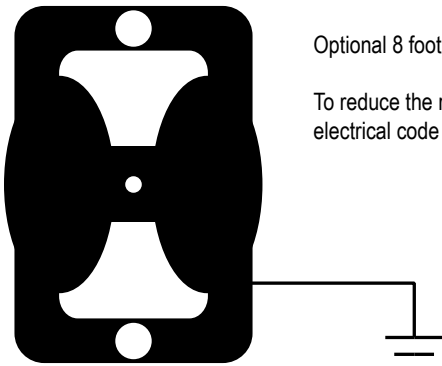

Optional 8 foot long (244 centimeters) Ground Strap is available for easy ground connection.

To reduce the risk of static electrical sparking, this pump must be grounded. Check the local electrical code for detailed grounding instruction and the type of equipment required.

WARNING



Take action to prevent static sparking. Fire or explosion can result, especially when handling flammable liquids. The pump, piping, valves, containers or other miscellaneous equipment must be grounded.

Table of Contents

SECTION 1: PUMP SPECIFICATIONS.....1

- Performance
- Materials
- Dimensional Drawings

SECTION 2: INSTALLATION & OPERATION.....4

- Principle of Pump Operation
- Typical Installation Guide
- Troubleshooting

SECTION 3: EXPLODED VIEW.....7

- Composite Drawings
- Parts List
- Materials Code

SECTION 4: CERTIFICATES11

- EC Declaration of Conformity - Directive 2006/42/EC - Machinery
- EC Declaration of Conformity - Directive 94/9/EC - ATEX
-  • EC Declaration of Conformity - Directive 1935/2004/EC - Food Contact Materials

1: PUMP SPECS

2: INSTAL & OP

3: EXP VIEW

4: CERTIFICATES

Performance

Model SPFP20NPS & SPFP20SSS
2" Food Processing
FDA SANTOPRENE FITTED

Flow Rate

Adjustable to 0-185 gpm (700 lpm)

Port Size

Suction 2½" Tri-Clamp

Discharge 2½" Tri-Clamp

Air Inlet 1/2" NPT

Air Exhaust 1" NPT

Suction Lift

Dry 17' (5.1 m)

Wet 32' (9.5 m)

Max Solid Size (Diameter)

. 1/4" (7.6 mm)

Max Noise Level 96 dB(A)

Shipping Weights

Stainless 106 lbs (48.1 kg)

1: PUMP SPECS

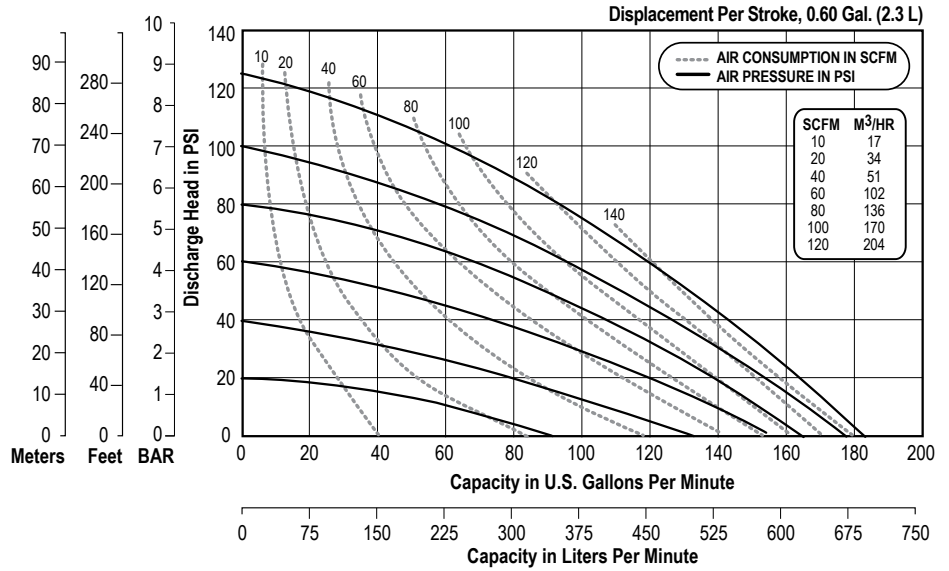

NOTE: Performance based on the following: elastomeric fitted pump, flooded suction, water at ambient conditions. The use of other materials and varying hydraulic conditions may result in deviations in excess of 5%.

Model SPFP20NPT & SPFP20SST
2" Food Processing
PTFE FITTED

Flow Rate

Adjustable to 0-153 gpm (579 lpm)

Port Size

Suction 2½" Tri-Clamp

Discharge 2½" Tri-Clamp

Air Inlet 1/2" NPT

Air Exhaust 1" NPT

Suction Lift

Dry 11' (3.3 m)

Wet 29' (8.8 m)

Max Solid Size (Diameter)

. 1/4" (7.6 mm)

Max Noise Level 102 dB(A)

Shipping Weights

Stainless 106 lbs (48.1 kg)

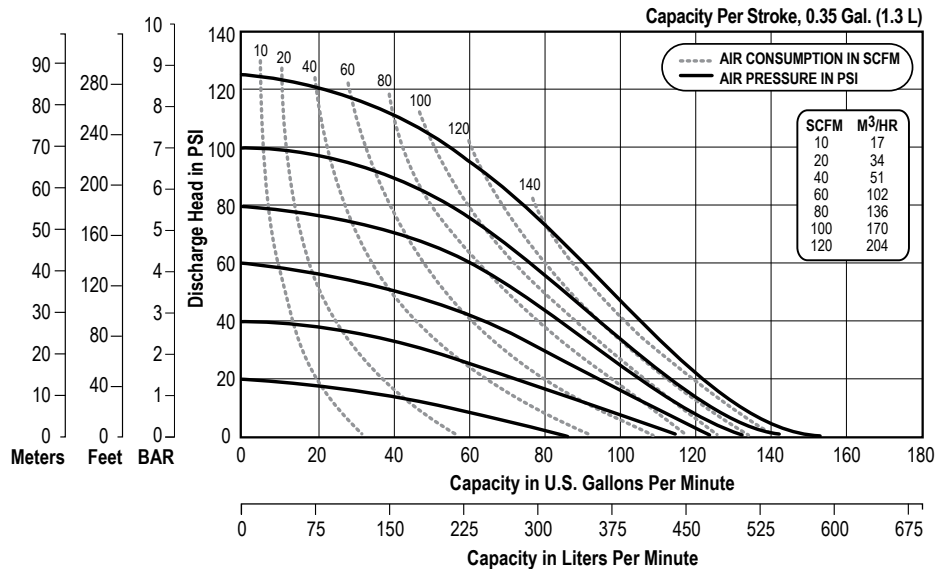

NOTE: Performance based on the following: PTFE fitted pump, flooded suction, water at ambient conditions. The use of other materials and varying hydraulic conditions may result in deviations in excess of 5%.

Materials

Material Profile:	Operating Temperatures:	
	Max.	Min.
<i>CAUTION! Operating temperature limitations are as follows:</i>		
Santoprene®: Injection molded thermoplastic elastomer with no fabric layer. Long mechanical flex life. Excellent abrasion resistance.	275°F 135°C	-40°F -40°C
Virgin PTFE: (PFA/TFE) Chemically inert, virtually impervious. Very few chemicals are known to chemically react with PTFE; molten alkali metals, turbulent liquid or gaseous fluorine and a few fluoro-chemicals such as chlorine trifluoride or oxygen difluoride which readily liberate free fluorine at elevated temperatures.	220°F 104°C	-35°F -37°C
<i>Maximum and Minimum Temperatures are the limits for which these materials can be operated. Temperatures coupled with pressure affect the longevity of diaphragm pump components. Maximum life should not be expected at the extreme limits of the temperature ranges.</i>		
Metals:		
Stainless Steel: Equal to or exceeding ASTM specification A743 CF-8M for corrosion resistant iron chromium, iron chromium nickel and nickel based alloy castings for general applicaitons. Commonly referred to as 316 Stainless Steel in the pump industry.		

Dimensional Drawings

Model SPFP20 Food Processing

Dimensions in inches (mm dimensions in brackets)

The dimensions on this drawing are for reference only. A certified drawing can be requested if physical dimensions are needed.

1: PUMP SPECS

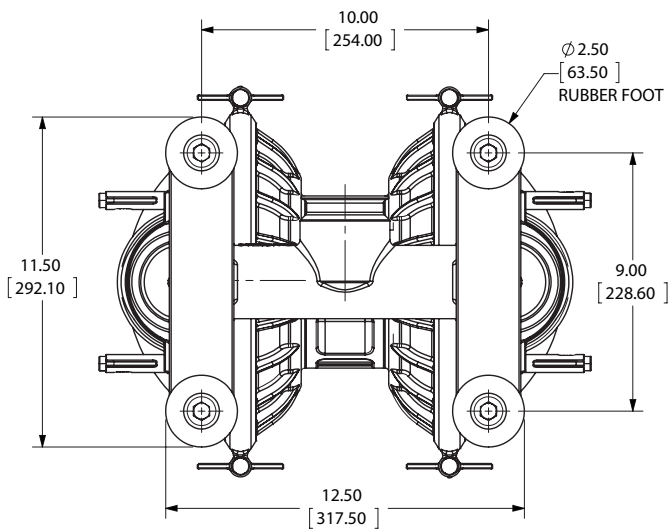
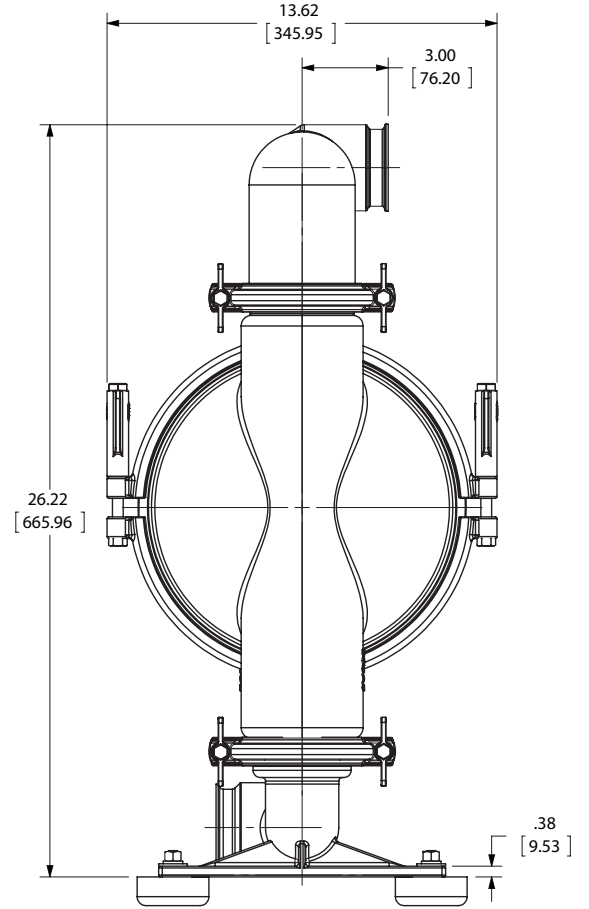
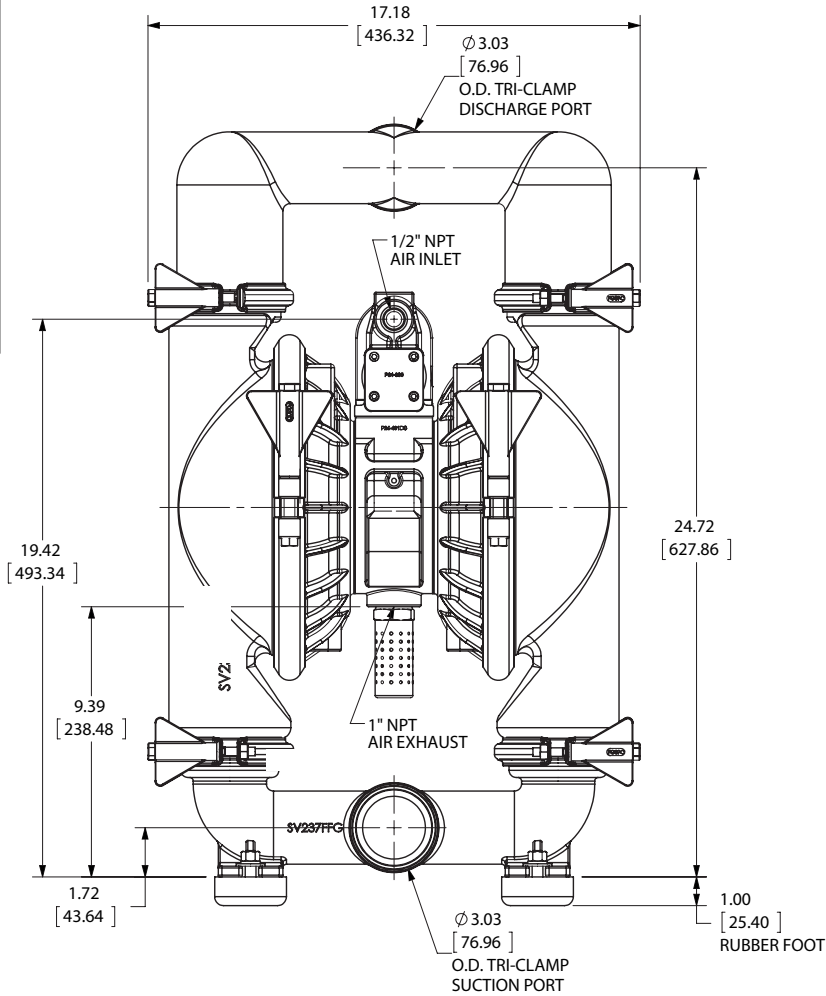

Principle of Pump Operation

Air-Operated Double Diaphragm (AODD) pumps are powered by compressed air or nitrogen.

The main directional (air) control valve ① distributes compressed air to an air chamber, exerting uniform pressure over the inner surface of the diaphragm ②. At the same time, the exhausting air ③ from behind the opposite diaphragm is directed through the air valve assembly(s) to an exhaust port ④.

As inner chamber pressure (P1) exceeds liquid chamber pressure (P2), the rod ⑤ connected diaphragms shift together creating discharge on one side and suction on the opposite side. The discharged and primed liquid's directions are controlled by the check valves (ball or flap) ⑥ orientation.

The pump primes as a result of the suction stroke. The suction stroke lowers the chamber pressure (P3) increasing the chamber volume. This results in a pressure differential necessary for atmospheric pressure (P4) to push the fluid through the suction piping and across the suction side check valve and into the outer fluid chamber ⑦.

Suction (side) stroking also initiates the reciprocating (shifting, stroking or cycling) action of the pump. The suction diaphragm's movement is mechanically pulled through its stroke. The diaphragm's inner plate makes contact with an actuator plunger aligned to shift the pilot signaling valve. Once actuated, the pilot valve sends a pressure signal to the opposite end of the main directional air valve, redirecting the compressed air to the opposite inner chamber.

SUBMERGED ILLUSTRATION

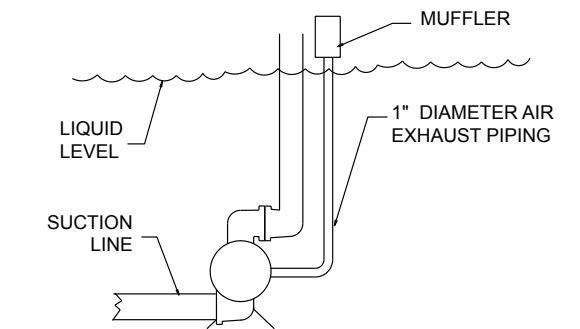

Pump can be submerged if the pump materials of construction are compatible with the liquid being pumped. The air exhaust must be piped above the liquid level. When the pumped product source is at a higher level than the pump (flooded suction condition), pipe the exhaust higher than the product source to prevent siphoning spills.

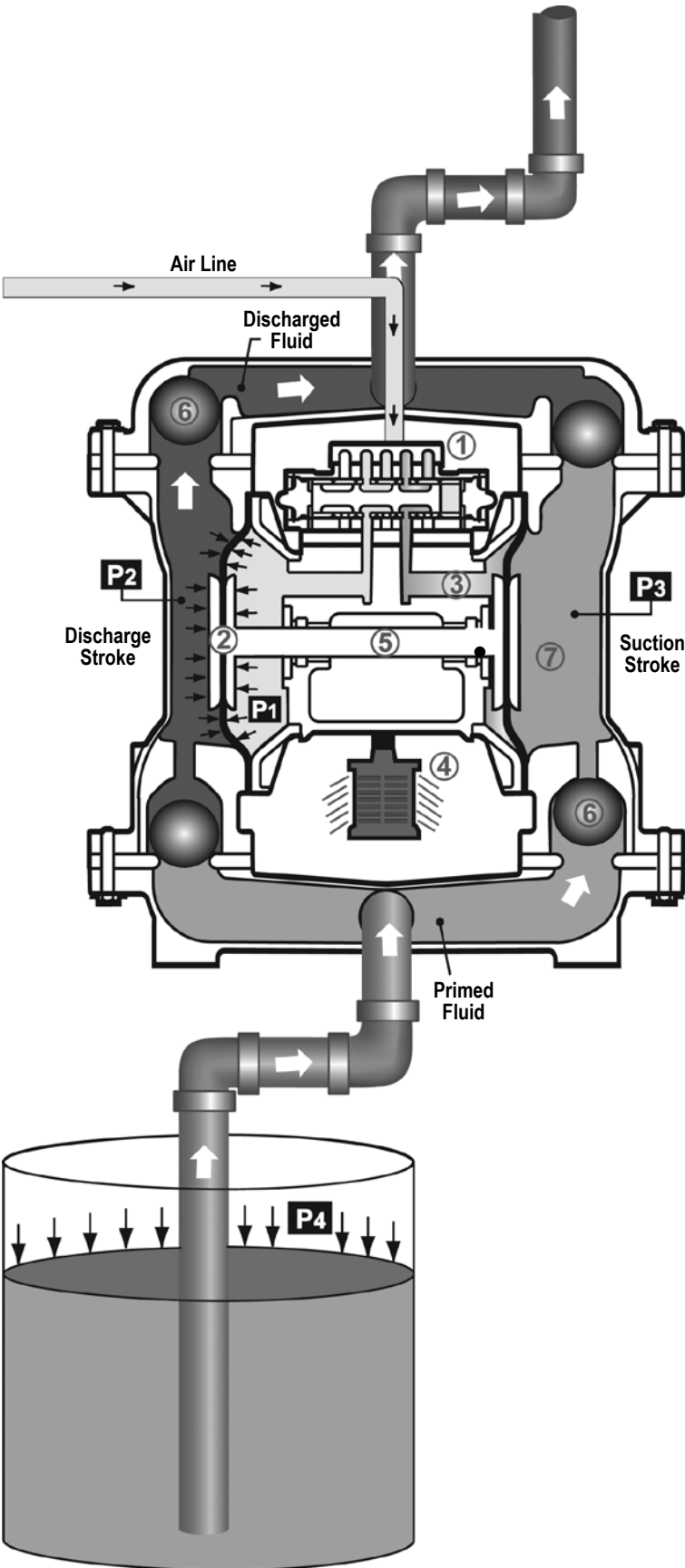

2: INSTAL & OP

Recommended Installation Guide

Available Accessories:

1. Surge Suppressor
2. Filter/Regulator
3. Air Dryer

Note: Surge Suppressor and Piping must be supported after the flexible connection.

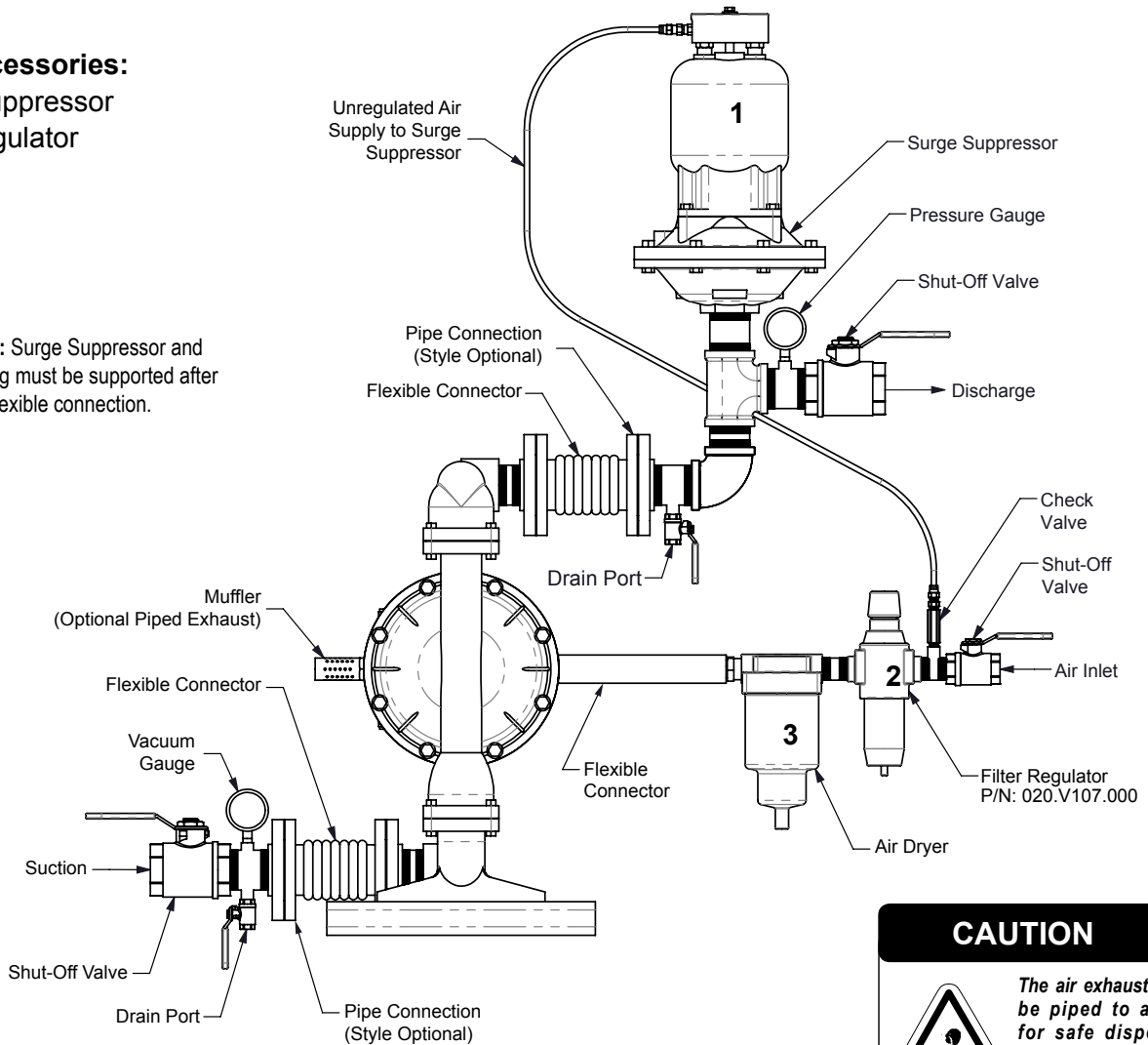

CAUTION



The air exhaust should be piped to an area for safe disposition of the product being pumped, in the event of a diaphragm failure.

Installation And Start-Up

Locate the pump as close to the product being pumped as possible. Keep the suction line length and number of fittings to a minimum. Do not reduce the suction line diameter.

Air Supply

Connect the pump air inlet to an air supply with sufficient capacity and pressure to achieve desired performance. A pressure regulating valve should be installed to insure air supply pressure does not exceed recommended limits.

Air Valve Lubrication

The air distribution system is designed to operate WITHOUT lubrication. This is the standard mode of operation. If lubrication is desired, install an air line lubricator set to deliver one drop of SAE 10 non-detergent oil for every 20 SCFM (9.4 liters/sec.) of air the pump consumes. Consult the Performance Curve to determine air consumption.

Air Line Moisture

Water in the compressed air supply may cause icing or freezing of the exhaust air, causing the pump to cycle erratically or stop operating. Water in the air supply can be reduced by using a point-of-use air dryer.

Air Inlet And Priming

To start the pump, slightly open the air shut-off valve. After the pump primes, the air valve can be opened to increase air flow as desired. If opening the valve increases cycling rate, but does not increase the rate of flow, cavitation has occurred. The valve should be closed slightly to obtain the most efficient air flow to pump flow ratio.

Troubleshooting Guide

Symptom:	Potential Cause(s):	Recommendation(s):
Pump Cycles Once	Deadhead (system pressure meets or exceeds air supply pressure).	Increase the inlet air pressure to the pump. Pump is designed for 1:1 pressure ratio at zero flow. (Does not apply to high pressure 2:1 units).
	Air valve or intermediate gaskets installed incorrectly.	Install gaskets with holes properly aligned.
	Bent or missing actuator plunger.	Remove pilot valve and inspect actuator plungers.
Pump Will Not Operate / Cycle	Pump is over lubricated.	Set lubricator on lowest possible setting or remove. Units are designed for lube free operation.
	Lack of air (line size, PSI, CFM).	Check the air line size and length, compressor capacity (HP vs. cfm required).
	Check air distribution system.	Disassemble and inspect main air distribution valve, pilot valve and pilot valve actuators.
	Discharge line is blocked or clogged manifolds.	Check for inadvertently closed discharge line valves. Clean discharge manifolds/piping.
	Deadhead (system pressure meets or exceeds air supply pressure).	Increase the inlet air pressure to the pump. Pump is designed for 1:1 pressure ratio at zero flow. (Does not apply to high pressure 2:1 units).
	Blocked air exhaust muffler.	Remove muffler screen, clean or de-ice, and re-install.
	Pumped fluid in air exhaust muffler.	Disassemble pump chambers. Inspect for diaphragm rupture or loose diaphragm plate assembly.
	Pump chamber is blocked.	Disassemble and inspect wetted chambers. Remove or flush any obstructions.
Pump Cycles and Will Not Prime or No Flow	Cavitation on suction side.	Check suction condition (move pump closer to product).
	Check valve obstructed. Valve ball(s) not seating properly or sticking.	Disassemble the wet end of the pump and manually dislodge obstruction in the check valve pocket. Clean out around valve ball cage and valve seat area. Replace valve ball or valve seat if damaged. Use heavier valve ball material.
	Valve ball(s) missing (pushed into chamber or manifold).	Worn valve ball or valve seat. Worn fingers in valve ball cage (replace part). Check Chemical Resistance Guide for compatibility.
	Valve ball(s)/seat(s) damaged or attacked by product.	Check Chemical Resistance Guide for compatibility.
	Check valve and/or seat is worn or needs adjusting.	Inspect check valves and seats for wear and proper setting. Replace if necessary.
	Suction line is blocked.	Remove or flush obstruction. Check and clear all suction screens or strainers.
	Excessive suction lift.	For lifts exceeding 20' of liquid, filling the chambers with liquid will prime the pump in most cases.
	Suction side air leakage or air in product.	Visually inspect all suction-side gaskets and pipe connections.
	Pumped fluid in air exhaust muffler.	Disassemble pump chambers. Inspect for diaphragm rupture or loose diaphragm plate assembly.
Pump Cycles Running Sluggish/Stalling, Flow Unsatisfactory	Over lubrication.	Set lubricator on lowest possible setting or remove. Units are designed for lube free operation.
	Icing.	Remove muffler screen, de-ice, and re-install. Install a point of use air drier.
	Clogged manifolds.	Clean manifolds to allow proper air flow
	Deadhead (system pressure meets or exceeds air supply pressure).	Increase the inlet air pressure to the pump. Pump is designed for 1:1 pressure ratio at zero flow. (Does not apply to high pressure 2:1 units).
	Cavitation on suction side.	Check suction (move pump closer to product).
	Lack of air (line size, PSI, CFM).	Check the air line size, length, compressor capacity.
	Excessive suction lift.	For lifts exceeding 20' of liquid, filling the chambers with liquid will prime the pump in most cases.
	Air supply pressure or volume exceeds system hd.	Decrease inlet air (press. and vol.) to the pump. Pump is cavitating the fluid by fast cycling.
	Undersized suction line.	Meet or exceed pump connections.
	Restrictive or undersized air line.	Install a larger air line and connection.
	Suction side air leakage or air in product.	Visually inspect all suction-side gaskets and pipe connections.
	Suction line is blocked.	Remove or flush obstruction. Check and clear all suction screens or strainers.
	Pumped fluid in air exhaust muffler.	Disassemble pump chambers. Inspect for diaphragm rupture or loose diaphragm plate assembly.
	Check valve obstructed.	Disassemble the wet end of the pump and manually dislodge obstruction in the check valve pocket.
	Check valve and/or seat is worn or needs adjusting.	Inspect check valves and seats for wear and proper setting. Replace if necessary.
Entrained air or vapor lock in chamber(s).	Purge chambers through tapped chamber vent plugs. Purging the chambers of air can be dangerous.	
Product Leaking Through Exhaust	Diaphragm failure, or diaphragm plates loose.	Replace diaphragms, check for damage and ensure diaphragm plates are tight.
	Diaphragm stretched around center hole or bolt holes.	Check for excessive inlet pressure or air pressure. Consult Chemical Resistance Chart for compatibility with products, cleaners, temperature limitations and lubrication.
Premature Diaphragm Failure	Cavitation.	Enlarge pipe diameter on suction side of pump.
	Excessive flooded suction pressure.	Move pump closer to product. Raise pump/place pump on top of tank to reduce inlet pressure. Install Back pressure device (Tech bulletin 41r). Add accumulation tank or pulsation dampener.
	Misapplication (chemical/physical incompatibility).	Consult Chemical Resistance Chart for compatibility with products, cleaners, temperature limitations and lubrication.
	Incorrect diaphragm plates or plates on backwards, installed incorrectly or worn.	Check Operating Manual to check for correct part and installation. Ensure outer plates have not been worn to a sharp edge.
Unbalanced Cycling	Excessive suction lift.	For lifts exceeding 20' of liquid, filling the chambers with liquid will prime the pump in most cases.
	Undersized suction line.	Meet or exceed pump connections.
	Pumped fluid in air exhaust muffler.	Disassemble pump chambers. Inspect for diaphragm rupture or loose diaphragm plate assembly.
	Suction side air leakage or air in product.	Visually inspect all suction-side gaskets and pipe connections.
	Check valve obstructed.	Disassemble the wet end of the pump and manually dislodge obstruction in the check valve pocket.
	Check valve and/or seat is worn or needs adjusting.	Inspect check valves and seats for wear and proper setting. Replace if necessary.
Entrained air or vapor lock in chamber(s).	Purge chambers through tapped chamber vent plugs.	

2: INSTAL & OP

Composite Repair Parts Drawing - FDA Santoprene Fitted

3: EXP VIEW

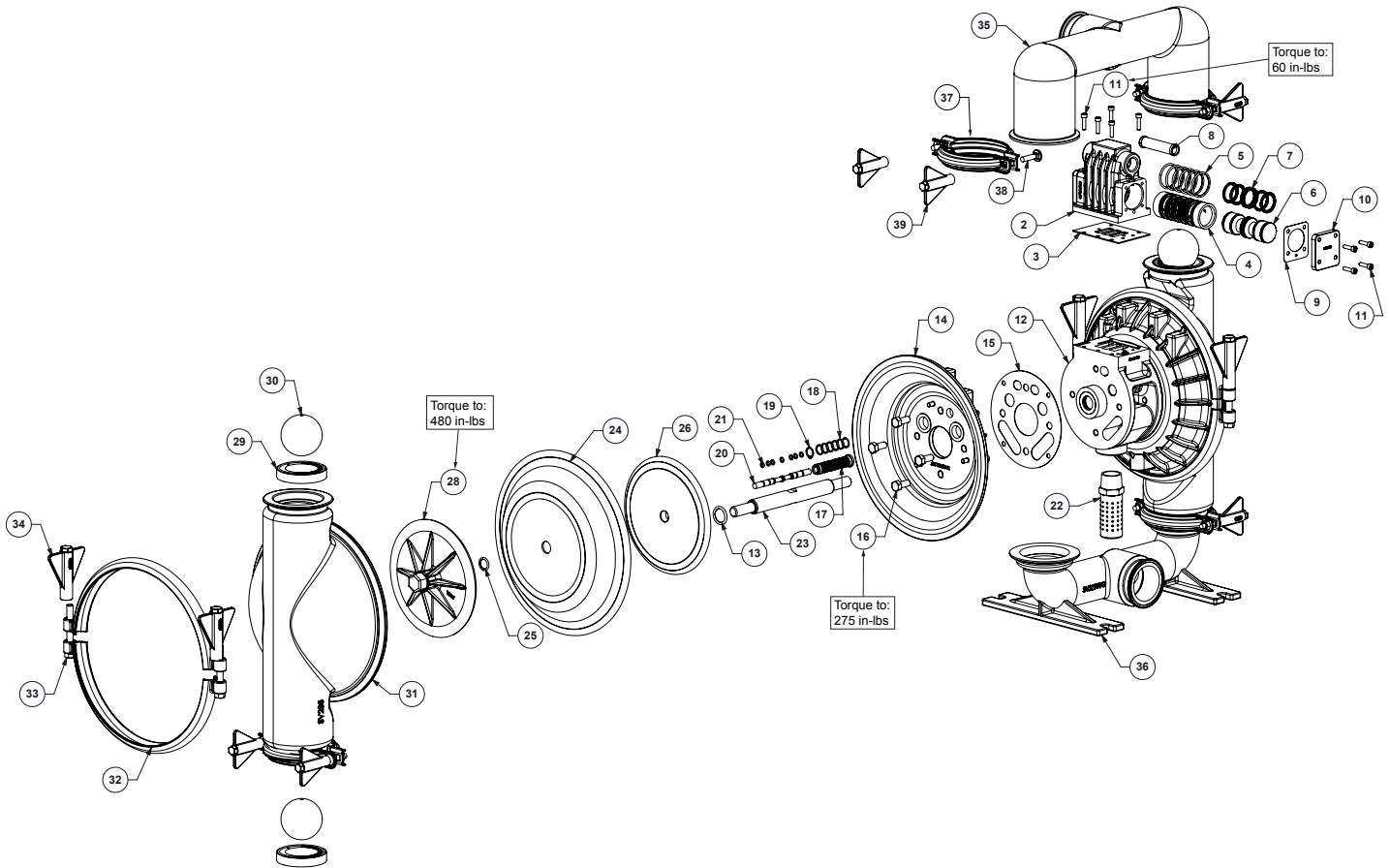

Composite Repair Parts List - FDA Santoprene Fitted

Air Valve Assembly				
Item #	Qty.	Description	Part Number	
			Nickle Plated	Stainless Steel
1	1	Valve Body (includes items 2-11)	200-201	200-430
2	1	Valve Body	200-206	200-431
3	1	Valve Body Gasket		200-277
4	1	Valve Sleeve		200-237
5	6	O-Ring		200-224
6	1	Valve Spool Assembly (Includes items 7)		200-238
7	6	Glyde Ring Assembly		200-307
8	1	Air Valve Screen	200-279	200-439
9	2	End Cap Gasket		200-278
10	2	End Cap		200-332
11	13	Mounting Screws		200-324
Center Section Assembly				
Item #	Qty.	Description	Part Number	
			Nickle Plated	Stainless Steel
12	1	Center Block Assembly (Includes item 13)	200-281	200-440
13	2	Main Shaft O-Ring		200-282
14	2	Air Chamber	200-210	200-432
15	2	Air Chamber Gasket	200-214	200-437
16	8	Bolt		200-327
17	1	Pilot Sleeve Assembly (include item 18)		200-232
18	6	O-Ring		200-223
19	1	Retaining Ring		200-227
20	1	Pilot Spool Assembly (Includes item 21)		200-239
21	7	O-Ring		200-221
22	1	Muffler		200-217
Diaphragm Assembly / Elastomers				
Item #	Qty.	Description	Part Number	
			Model SPFP20NPS FDA Santoprene	Model SPFP20SSS FDA Santoprene
23	1	Main Shaft		200-272
24	2	Diaphragm		200-397
25	2	O-Ring		200-394
26	2	Inner Diaphragm Plate	200-424	200-445
27	2	Bumper Washer		N/A
28	2	Outer Diaphragm Plate		200-381
29	4	Valve Seat		200-398
30	4	Valve Ball		200-400
Wet End Assembly				
Item #	Qty.	Description	Part Number	
31	2	Water Chamber	200-359	
32	4	Large Clamp Half	200-357	
33	4	Bolt	200-358	
34	4	Wing Nut	200-269	
35	1	Discharge Manifold	200-360	
36	1	Suction Manifold	200-361	
37	8	Small Clamp Half	200-362	
38	8	Bolt	200-363	
39	8	Wing Nut	200-270	
Parts Not Shown For Rubber Mounting Feet				
Qty.	Description	Part Number		
4	Foot, Mounting	200-212		
4	Capscrew, Hex Head	200-209		
4	Nut, Hex	200-219		
4	Lockwasher	200-243		
8	Flatwasher	200-244		

3: EXP VIEW

Composite Repair Parts Drawing - PTFE Fitted

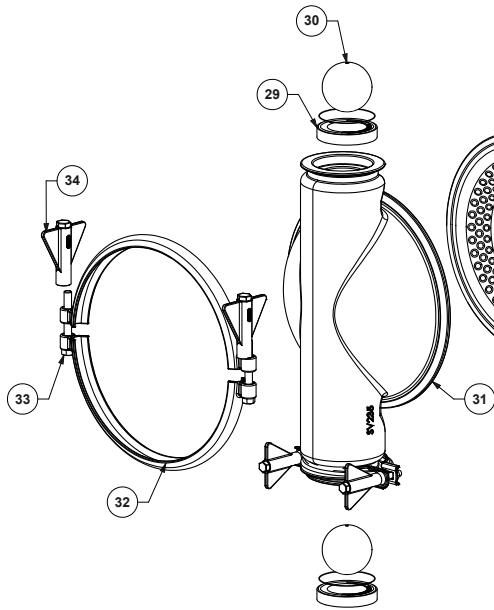
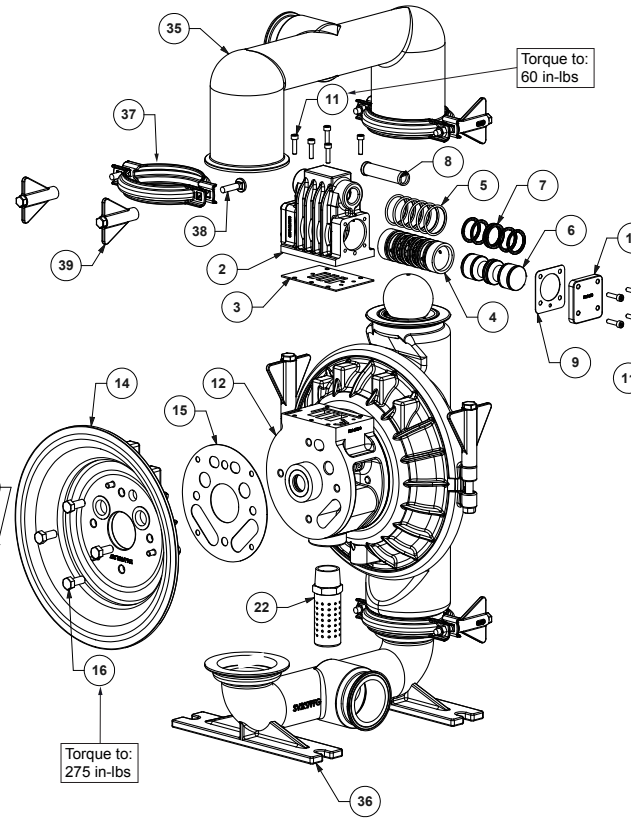
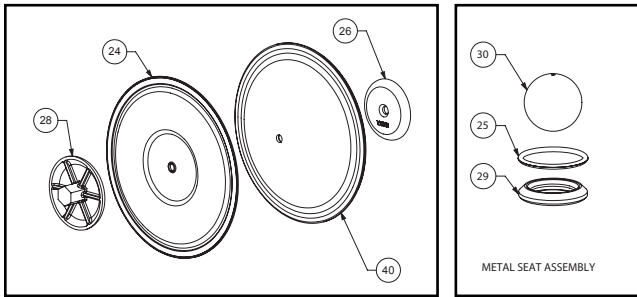

3: EXP VIEW

Composite Repair Parts List - PTFE Fitted

Air Valve Assembly						
Item #	Qty.	Description	Part Number			
			Nickle Plated		Stainless Steel	
1	1	Valve Body (includes items 2-11)	200-201		200-428	
2	1	Valve Body	200-206		200-431	
3	1	Valve Body Gasket		200-277		
4	1	Valve Sleeve		200-237		
5	6	O-ring		200-224		
6	1	Valve Spool Assembly (Includes items 7)		200-238		
7	6	Glyde Ring Assembly		200-307		
8	1	Air Valve Screen	200-279		200-439	
9	2	End Cap Gasket		200-278		
10	2	End Cap		200-332		
11	13	Mounting Screws		200-324		
Center Section Assembly						
Item #	Qty.	Description	Part Number			
			Nickle Plated		Stainless Steel	
12	1	Center Block Assembly (Includes item 13)	200-281		200-440	
13	2	Main Shaft O-Ring		200-282		
14	2	Air Chamber	200-210		200-432	
15	2	Air Chamber Gasket	200-214		200-437	
16	8	Bolt		200-327		
17	1	Pilot Sleeve Assembly (include items 18 & 19)		200-232		
18	6	O-ring		200-223		
19	1	Retaining Ring		200-227		
20	1	Pilot Spool Assembly (Includes item 21)		200-239		
21	7	O-ring		200-221		
22	1	Muffler		200-217		
Diaphragm Assembly / Elastomers						
Item #	Qty.	Description	Part Number			
			Model SPFP20NPT	Model SPFP20NPP	Model SPFP20SST	MODEL SPFP20SSP
23	1	Main Shaft	200-273	200-436	200-273	200-436
24	2	Diaphragm	200-396	200-456	200-396	200-456
40	2	Back-Up Diaphragm	N/A	200-457	N/A	200-457
25	2	O-Ring		200-425		
26	2	Inner Diaphragm Plate	N/A	200-454	N/A	200-446
27	2	Bumper Washer		200-283		
28	2	Outer Diaphragm Plate	N/A	200-447	N/A	200-447
29	4	Valve Seat		200-364 (See note 1)		
30	4	Valve Ball		200-399		
Wet End Assembly						
Item #	Qty.	Description	Part Number			
31	2	Water Chamber		200-359		
32	4	Large Clamp Half		200-357		
33	4	Bolt		200-358		
34	4	Wing Nut		200-269		
35	1	Discharge Manifold		200-360		
36	1	Suction Manifold		200-361		
37	8	Small Clamp Half		200-362		
38	8	Bolt		200-363		
39	8	Wing Nut		200-270		
	2	Diaphragm Seal Tape Kit (Not Pictured)		200-230		
Parts Not Shown For Rubber Mounting Feet						
Qty.	Description	Part Number				
4	Foot, Mounting	200-212				
4	Capscrew, Hex Head	200-209				
4	Nut, Hex	200-219				
4	Lockwasher	200-243				
8	Flatwasher	200-244				

Notes:

1.) In addition to this seat, (4) 200-425 o-rings are needed.

3: EXP VIEW

DECLARATION OF CONFORMITY

DECLARATION DE CONFORMITE • DECLARACION DE CONFORMIDAD • ERKLÄRUNG BEZÜGLICH EINHALTUNG DER VORSCHRIFTEN
DICHIARAZIONE DI CONFORMITÀ • CONFORMITEITSVERKLARING • DEKLARATION OM ÖVERENSSTÄMMELSE
EF-OVERENSSTEMMELSESERKLÄRING • VAATIMUSTENMUKAISUUSVAKUUTUS • SAMSVARSERKLÄRING
DECLARAÇÃO DE CONFORMIDADE

MANUFACTURED BY:

FABRIQUE PAR:
FABRICADA POR:
HERGESTELLT VON:
FABBRICATO DA:
VERVAARDIGD DOOR:
TILLVERKAD AV:
FABRIKANT:
VALMISTAJA:
PRODUSENT:
FABRICANTE:

STANDARD PUMP, INC.®
1610 Satellite Blvd., Suite D
Duluth, GA 30097
USA
Tel: 770-307-1003

STANDARD
Pump, Inc.

**PUMP MODEL SERIES: SPFP05, SPFP10, SPFP15, SPFP20, SPFP30,
SPSN15, SPSN20, SP3A15, SP3A20**

This product complies with the following European Community Directives:

Ce produit est conforme aux directives de la Communauté européenne suivantes:
Este producto cumple con las siguientes Directrices de la Comunidad Europea:
Dieses produkt erfüllt die folgenden Vorschriften der Europäischen Gemeinschaft:
Questo prodotto è conforme alle seguenti direttive CEE:
Dir produkt voldoet aan de volgende EG-richtlijnen:
Denna produkt överensstämmer med följande EU direktiv:
Standard Pump, Inc., erklærer herved som fabrikant, at ovennævnte produkt er i overensstemmelse med bestemmelserne i Direktive:
Tämä tuote täyttää seuraavien EC Direktiivien vaatimukset:
Dette produkt oppfyller kravene til følgende EC Direktiver:
Este produto está de acordo com as seguintes Directivas comunitárias:

2006/42/EC
on Machinery, according
to Annex VIII

This product has used the following harmonized standards to verify conformance:

Ce matériel est fabriqué selon les normes harmonisées suivantes, afin d' en garantir la conformité:
Este producto cumple con las siguientes directrices de la comunidad europea:
Dieses produkt ist nach folgenden harmonisierten standards gefertigt worden, die übereinstimmung wird bestätigt:
Questo prodotto ha utilizzato i seguenti standards per verificare la conformità:
De volgende geharmoniseerde normen werden gehanteerd om de conformiteit van dit produkt te garanderen:
För denna produkt har följande harmoniserande standarder använts för att bekräfta överensstämmelse:
Harmoniserede standarder, der er benyttet:
Tässä tuotteessa on sovellettu seuraavia yhdenmukaistettuja standardeja:
Dette produkt er produsert i overensstemmelse med følgende harmoniserte standarder:
Este produto utilizou os seguintes padrões harmonizados para varificar conformidade:

EN809:1998+
A1:2009

AUTHORIZED/ APPROVED BY:

Approuve par:
Aprobado por:
Genehmigt von:
approvato da:
Goedgekeurd door:
Underskrift:
Valtuutettuna:
Bemyndiget av:
Autorizado Por:

Chris Murphy
Chris Murphy
Director of Operations

DATE: July 20, 2012

FECHA:
DATUM:
DATA:
DATO:
PÄIVÄYS:

CE

DECLARATION OF CONFORMITY WITH ATEX 95 DIRECTIVE



Date of Issue:	10 May 2014
Technical File No.:	203104000-1410/MER
Quality System Registration No:	ISO 9001-2000
Directive:	94/9/EC 23 March 1994 Annex VIII
Conforming Apparatus:	Air-Operated Metal Double Diaphragm Pumps for Use In Potentially Explosive Atmospheres
Hazardous Location Applied:	 II 2 G c T5 II 2 D c T100°C T5 fluids up to 95° C
Manufacturer:	Standard Pump, Inc. 1610 Satellite Blvd., Suite D Duluth, GA 30097 USA
On File With:	DEKRA Certification B.V. (0344) Meander 1051 6825 MJ Arnhem The Netherlands
Harmonized Standards Applied:	BS EN 13463-1:2009 Non-Electrical Equipment Potentially Explosive Atmospheres-Part 1 Basic Methods and Requirements EN 13463-5:2011 Non-Electrical Equipment for Potentially Explosive Atmospheres-Part 5 Protection by Constructional Safety
Equipment:	SPFP20, SPFP30, SPSN20, SPFP15, SPSN15

We hereby certify that the above apparatuses described above conforms with the protection requirements of Council Directive 94/9/EC of 23 March 1994 Annex VIII on the approximation of the laws of the Member States Concerning Equipment and Protective Systems Intended for use in Potentially Explosive Atmospheres

DATE/OF REVISION/TITLE:
13 October 2015

Chris Murphy
Director of Operations

STANDARD
Pump, Inc.



Declaration of Conformity

Manufacturer:

Standard Pump, Inc.

1610 Satellite Blvd., Suite D, Duluth, GA 30097, USA

certifies that Air-Operated Double Diaphragm
Food Processing and Sanitary Pump Models comply with the European
Community Regulation 1935/2004/EC for Food Contact Materials.

Food Processing Pump Models:

SPFP05PPS	SPFP30NPS
SPFP10PPS	SPFP30SSS
SPFP15NPS	SPFP05PPP
SPFP20NPS	SPFP10PPP
SPFP20SSS	SPFP15NPP
SPFP30NPT	SPFP20NPP
SPFP30SST	SPFP20SSP

Sanitary Pump Models:

SPSN15NPS
SPSN20NPS
SPSN20SSS
SPSN15NPP
SPSN20NPP
SPSN20SSP

Chris Murphy
Signature of authorized person

Chris Murphy
Printed name of authorized person

Revision Level: B

September 11, 2013
Date of issue

Director of Operations
Title

October 13, 2015
Date of revision

