



Technical Specifications

Package Includes:..... Motor, Pump Tube, Hose, Storage Bracket, Barrel Adapter & Hand Nozzle

Motor Type:..... 220V, IP54 (825 W) or IP54 (450W)

Pump Tube Material:..... PVDF, Hastelloy C-276, Carbon Graphite

Immersion Length:..... 39" (1000 mm) or 47" (1200 mm)

Discharge Hose: Modified Cross-Link Polyethylene, 6 ft (1,8 m), 1" (25 mm) I.D.

Hand Nozzle Material: PVDF, Viton

Maximum Flow Rate:..... 15 GPM (57 LPM) *based on water*

Maximum Viscosity: 1500 cps (mPas)

Maximum Temperature: 175° F (80° C)

Shipping Weight:..... 30 lbs. (13,60 kg)

RECOGNIZED COMPONENT



Intertek

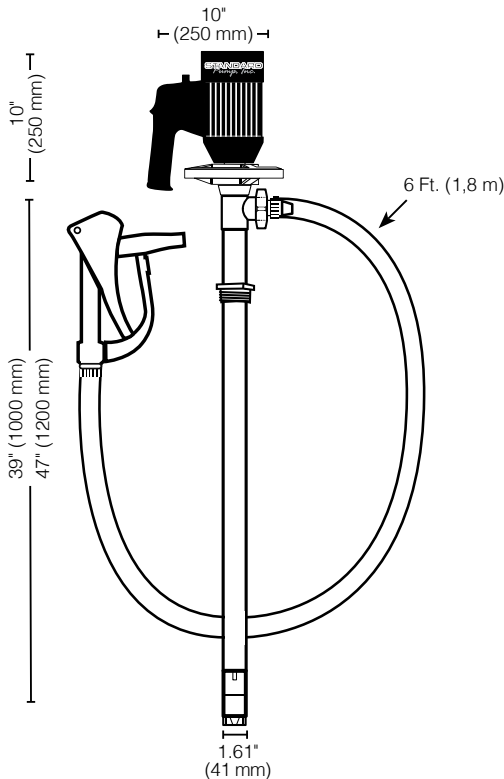

DRUMS

Package P/N	Motor	Power	Pump Tube
9421A	SP-ENC-2-V	825 W	SP-PVDF-39
9421B	SPE-450V	450 W	SP-PVDF-39

IBC TANKS

Package P/N	Motor	Power	Pump Tube
9423A	SP-ENC-2-V	825 W	SP-PVDF-47
9423B	SPE-450V	450 W	SP-PVDF-47



Warning: This pump is not suitable for use with Flammable/Combustible liquids.

*Note: When pumping viscosities over 1,000 cps, pump must be used intermittently to avoid potential premature failure and/or damage.