



## Technical Specifications

**Package Includes:**..... Motor, Pump Tube, Hose, Storage Bracket, Flow Meter, Barrel Adapter & Hand Nozzle

**Motor Type:**..... 220V, IP44 (825 W) or IP54 (450W)

**Pump Tube Material:**.. Polypropylene, Hastelloy C-276, Carbon Graphite

**Immersion Length:**..... 39" (1000 mm) or 47" (1200 mm)

**Discharge Hose:** .....PVC, (1,8 m), 1" (25 mm) I.D.

**Hand Nozzle Material:** .....Polypropylene, Viton

**Flow Meter Material:** ..... Polypropylene, HC22, PTFE

**Flow Meter Type:**.....Digital / Battery Powered Totalizer

**Maximum Flow Rate:**..... 51 l/min *based on water*

**Maximum Viscosity:** ..... 300 cps (mPas)

**Maximum Temperature:** .....55°C

**Shipping Weight:**.....10,43 kg

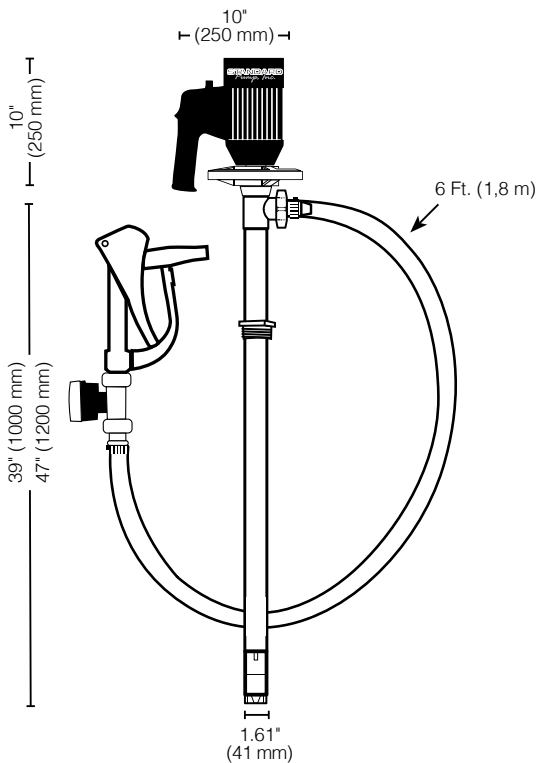

## DRUMS

Package P/N	Motor	Power	Pump Tube
9501A	SP-280P-2-V	825 W	SP-PP-39
9501-D	SPE-450V	825 W	SP-PP-39

## IBC TANKS

Package P/N	Motor	Power	Pump Tube
9503A	SP-280P-2-V	825 W	SP-PP-47
9503-D	SPE-450V	825 W	SP-PP-47



**Warning: This pump is not suitable for use with Flammable/Combustible liquids.**

\*Note: When pumping viscosities over 1,000 cps, pump must be used intermittently to avoid potential premature failure and/or damage.